

PART VALUES NEED ADJUSTMENT

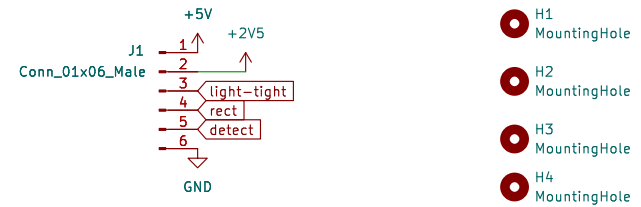
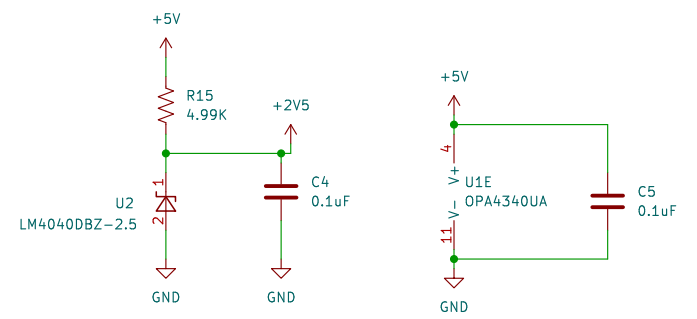
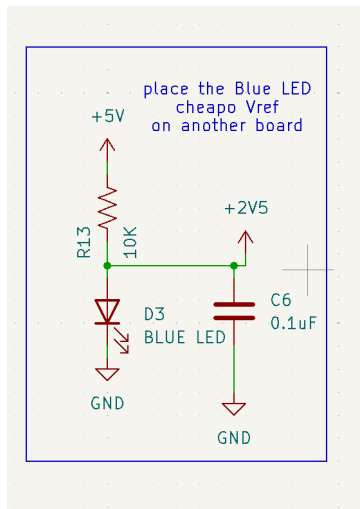
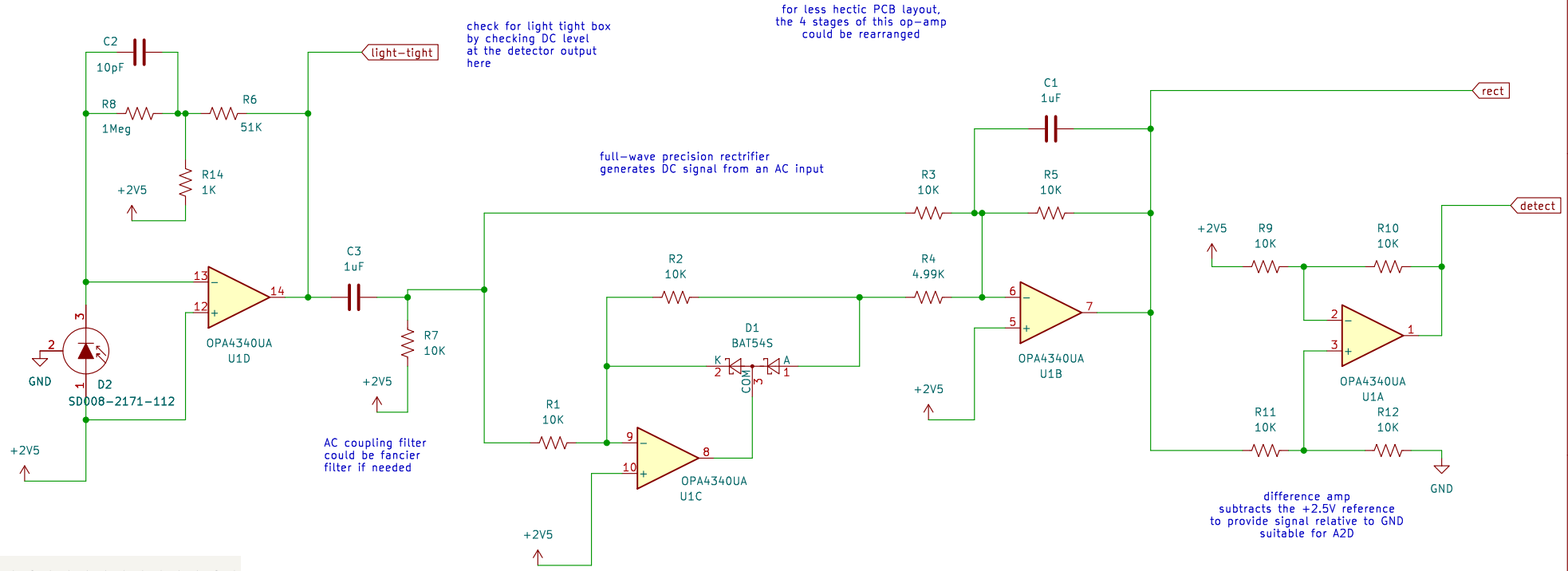

Sheet: /		Date:	
File: UV-Detector-v0.2.kicad_sch		Rev:	
Size: A4	KiCad E.D.A. 8.0.0		Id: 1/1